

Peso: 1568 kg

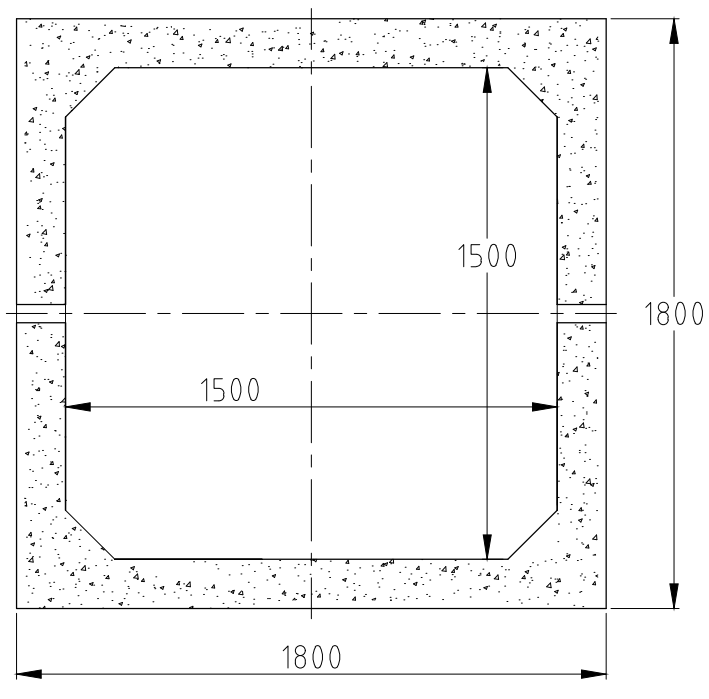

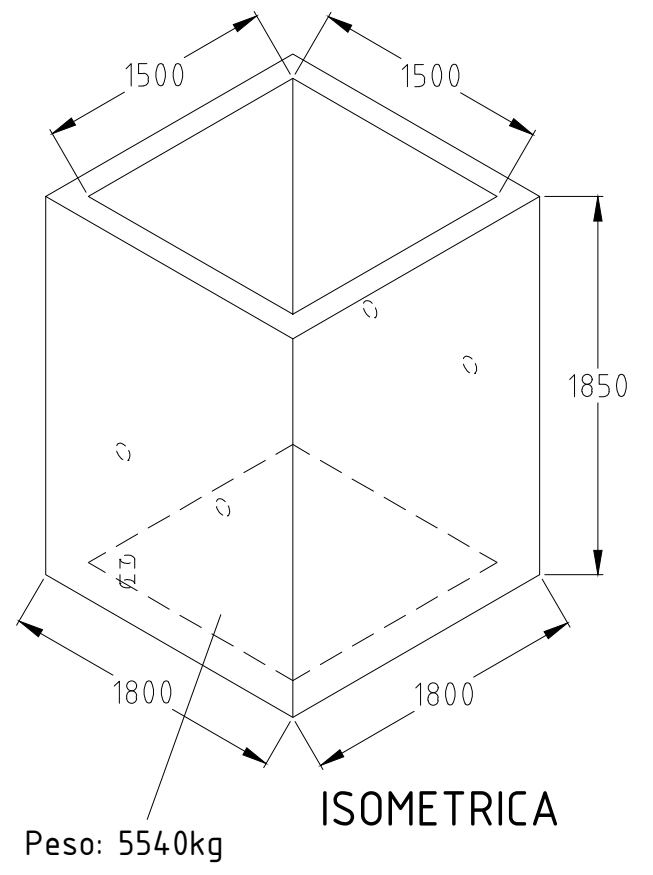
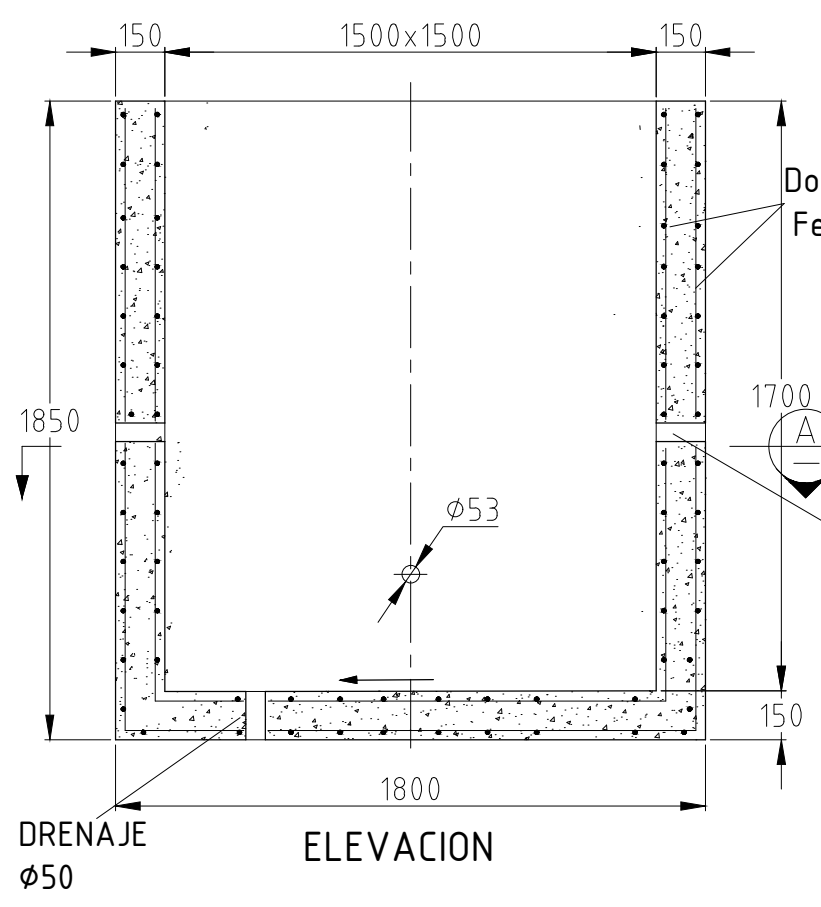
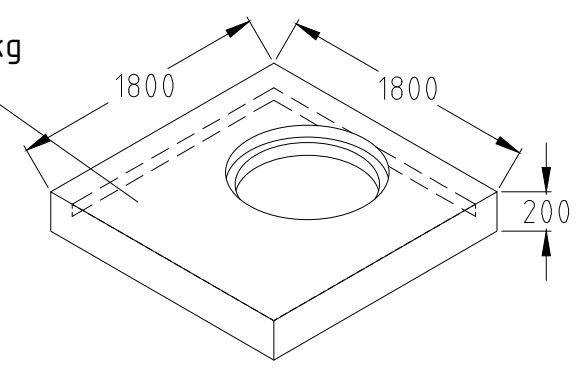

SECCION PLANTA  $\text{\textcircled{A}}$

**MATERIALES**

HORMIGON : G-30  
ACERO : A630-420

**NOTA**

SE CONSIDERAN PERFORACIONES EN 3 CARAS DEL MURO, DETALLE A CONFIRMAR POR CLIENTE.

INGENIERIA Y PROYECTOS					 Prefabricados de Hormigón 	DESCRIPCION:		<b>CAMARA ELECTRICA</b> <b>1500 x 1500 x 1700</b>	
	edición	modificación	fecha	nombre		Nº PLANO			REVISION
	NOMBRE		FECHA						
	Dibujó:					ESCALAS:	 $\text{\textcircled{A}}$		
Proyectó:				INDICADAS					
Aprobó:	V. valdés	09-11-23							